

POWERBOAT HANDLING TRAINER



Safe powerboat handling requires an understanding of variable and complex problems. Boat handling skills can only be developed through hands-on- experience. In the past, this experience could only be gained from actual operation of a full size powerboat. The **Dietz Powerboat Trainer** now makes it possible to gain experience in powerboat handling in a boat dealer's showroom, in the classroom, or at home.

The Powerboat Trainer duplicates a **control station**, containing two clutches, two throttles, and steering wheel similar to what is found on a full size twin engine powerboat. It also contains an FM transmitter and a digital proportional radio control system. It can be operated from an internal battery or from a 120 volt AC electric outlet.

The twin engine powerboat is 45 inches long and has a 14 inch beam. It is equipped with a system that uses the signals from the narrow-band transmitter in the control station to send signals to its dual conversion receiver for smooth control. The boat is

equipped with one servo to control the steering and two computers which control the operation of the two electric motors. The powerboat is powered by a 12 volt DC, 18 ampere hours sealed gel battery. This battery can be easily removed when the LED indicator flashes, and be replaced by a freshly charged spare battery. The boat is provided with an on/off switch, LED indicator, and a recharging jack that allows recharging when a single battery is used. When the LED indicator is on, the boat can be operated. It will blink when the battery is low to indicate a discharged battery. The powerboat components are all controlled by the two clutches, two throttles, and steering wheel located on the control station. The FM radio receiver passes a signal to the steering servo which is attached to the rudders. The receiver also passes signals to the computer operated speed controls which in turn controls the motors. The motors have a magnetic collar on their shafts and a magnetic sensor which allows the computers to synchronize the motion of the two motors.

The boat is supplied with a cradle used when a battery in the boat requires recharging. Boat should



View of powerboat and control station



THE HENRY G. DIETZ CO., INC.

14-26 28th Avenue

Long Island City, New York 11102-3692, U.S.A.

Tel: (718) 726-3347 or (718) 726-7270 Fax: (718) 728-3976

E mail: hgdietz@lowpressure.com

URL: www.lowpressure.com

POWERBOAT HANDLING TRAINER

be taken out of the water when battery is being charged. If spare batteries are used, batteries can be replaced while boat is in the water.

Two battery chargers are supplied. The large charger is used in charging spare batteries or the battery in the boat. The small charger should be used to power the control station during operation or to charge the control station for battery operation.

The Powerboat Handling Trainer can be used in a family back yard pool, or by purchasing an outdoor plastic pool (120"x72"x22" for approximately \$50). Boat dealers can have an 8 foot square table type pool fabricated locally. Details for its construction can be supplied.

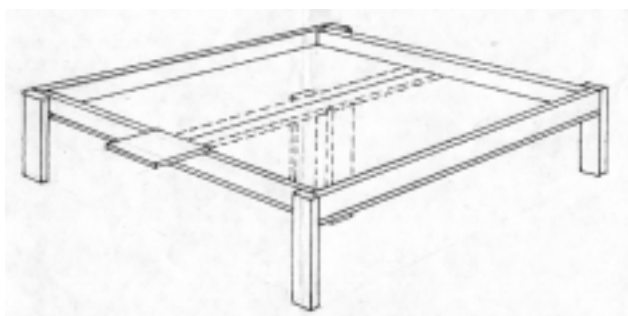

Table Type Pool (8 feet by 8 feet, 3 feet high) best suited for dealer showroom or classroom use.

The Powerboat Handling Trainer can be used to gain the experience and the confidence to perform a variety of basic and complicated maneuvers needed to take a boat out of its slip and bring it back safely. Oral instructions in the classroom do not put the basic knowledge into practice, for it is necessary to learn through hands on repetition the functions of the throttle, the clutch, and steering wheel. Learning can be enjoyable if the **Powerboat Handling Trainer** is used, for what could be disastrous practicing with a full size boat in close quarters, will result in no damage when using the 45 inch length trainer powerboat before setting sail.

The embarrassment of things going wrong when trying to dock can be greatly reduced by the knowledge gained from using the trainer.

The Henry G. Dietz Co., Inc. has a free
“Powerboat Handling Manual”
that can be downloaded by going to:
www.powerboat-handling.com

Note: Use of the Powerboat Handling Trainer is to teach the basic principles of powerboat handling. The Powerboat Handling Trainer is not a substitute for the experience obtained by operation of a full size powerboat. Each powerboat has its own reaction to its controls that can only be learned by actual operating experience.



THE HENRY G. DIETZ CO., INC.

14-26 28th Avenue

Long Island City, New York 11102-3692, U.S.A.

Tel: (718) 726-3347 or (718) 726-7270 Fax: (718) 728-3976

E-mail: hgdietz@lowpressure.com

URL: www.lowpressure.com