

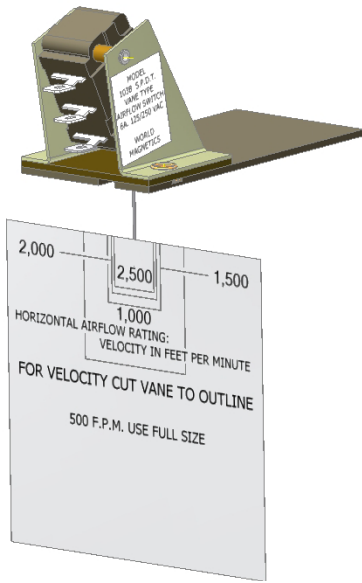

Model 103B

Dietz Vane Type Airflow Switch



- Vane-operated device for detecting airflow
- Guards against failures in air-cooled electronic equipment
- Easy installation - mounts directly on horizontal air duct
- Switch actuates / de-actuates when vane is moved by specified airflow velocity
- Snap action switch is enclosed in a plastic dust cover and fitted with aluminum mounting brackets
- Gold contacts available for low voltage and current
- Model 103B-MF is treated to resist moisture and fungus

Specifications

Operating Range:

Minimum Velocity – 500 feet per minute

Maximum Velocity – 2,500 feet per minute

Construction:

Snap-action switch is enclosed in a plastic dust cover and fitted with aluminum mounting brackets

Stainless steel vane and actuating lever wire

Aluminum parts anodized in accordance with MIL-A-8625 Class 2, Type 1

Electrical Ratings:

6 amps 250 volts AC

Single pole, double throw contacts

Contact Materials:

Silver alloy

Terminals:

.187 x .02 quick connect

Installation:

The switch is mounted directly on a horizontal air duct. Switch body must be facing upward or perpendicular to airflow. Note: Switch cannot be used in airflow projecting downward and performs best in laminar airflow stream.



Model 103B

Dietz Vane Type Airflow Switch

OPERATING RANGE:

MINIMUM VELOCITY: 500 FEET PER MINUTE
MAXIMUM VELOCITY: 2,500 FEET PER MINUTE
SEE TABLE (SHEET 2) FOR SPECIFIC OPERATING AND RELEASE AIR FLOW VELOCITIES.

ELECTRICAL:

6 AMP, 125/250 VAC
CONFIGURATION: SPDT SNAP ACTION SWITCH
CONTACT MAT'L: SILVER ALLOY
TERMINALS: .187 x .02 QUICK CONNECT

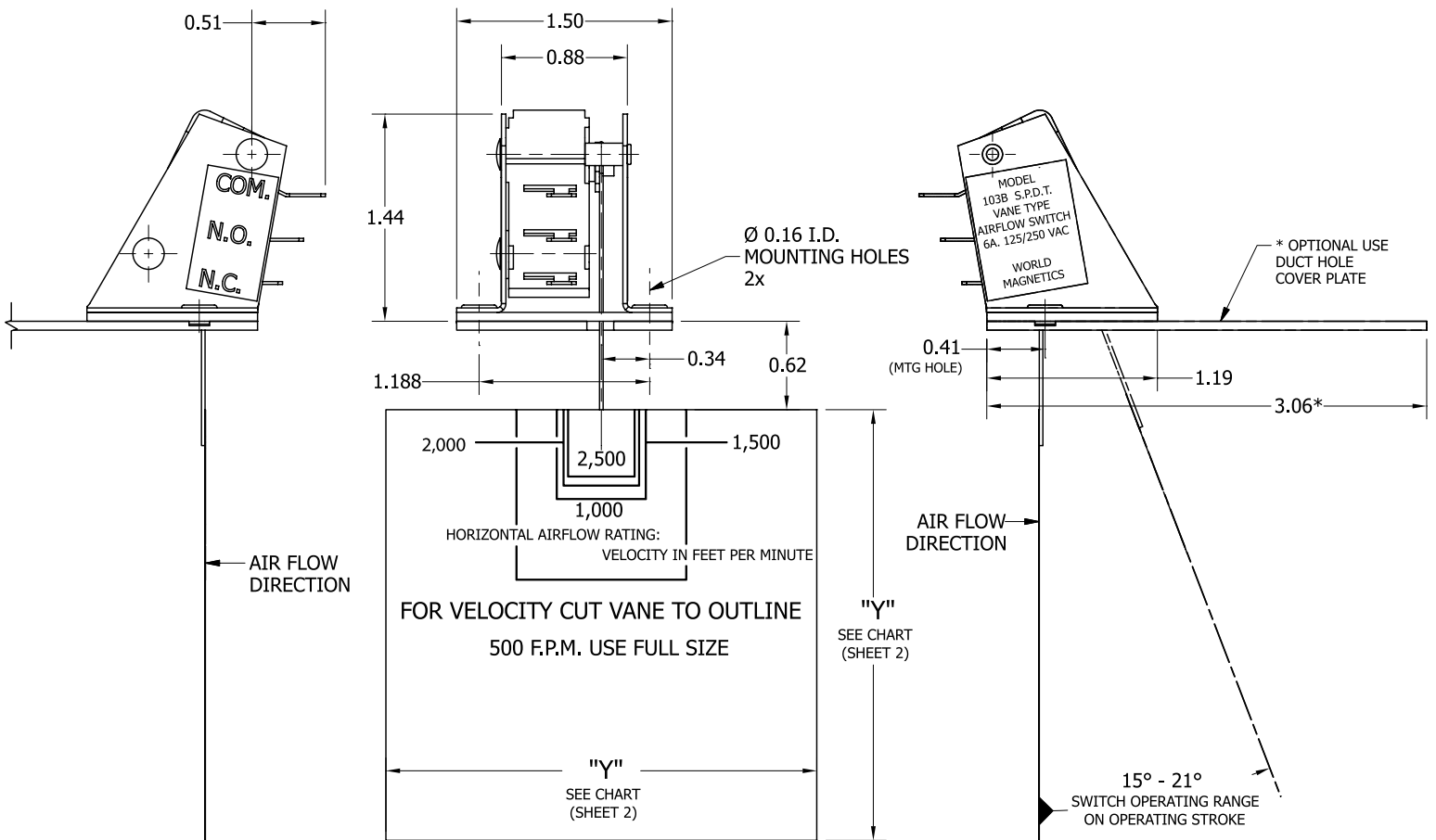



Model 103B

Dietz Vane Type Airflow Switch

AIR FLOW DIRECTION & VELOCITY (FT/MIN) - VANE SIZE and DUCT CUT-OUT					
AIR FLOW HORIZONTAL OPERATING	AIR FLOW HORIZONTAL RELEASE	AIR FLOW VERTICAL OPERATING	AIR FLOW VERTICAL RELEASE	DIMENSION "X" (SHT 2) DUCT SLOT	DIMENSION "Y" (SHT 1) VANE SIZE
500	400	800	700	2.50	3.00
1000	850	1000	850	0.81	1.187
1500	1350	1500	1350	0.53	0.625
2000	1850	2000	1850	0.53	0.531
2500	2400	2500	2400	0.53	0.468

AIR DUCT DRILL TEMPLATE
SCALE 1 : 1

